



特點

- 特別適用於電鍍液、化學液、純水循環過濾等用途。
- 採用無軸封磁力泵，確保無洩漏。
- 濾心式設計，高精度過濾，過濾面積廣，效率高，操作簡便、清洗容易，成本低。
- 過濾筒主體採用GF-PP材料制成。

FEATURES

- Especially suitable for plating solution, chemical liquid, pure water circulation filter purposes.
- Without the magnetic pump shaft seal, ensure no leakage.
- Filter heart type design, precision filtration, filtering area wide, high efficiency, simple operation, easy to clean, low cost.
- Filter cartridges subject using GF-PP material is made.



型號意義 MODEL EXPLANATION

TFX-2006-P-F-N-B

① ② ③ ④ ⑤ ⑥

- ①：機型型號 Model
- ②：2006:濾心數量20"×6支 Filter element quantity 20"×6pc
- ③：P：泵體材質 GF-PP Pump material GF-PP
- ④：F：出入口法蘭式 Flange type outlet/inlet
U：出入口由任式 Union type outlet/inlet
- ⑤：N：密封橡膠NBR Seal rubber NBR
V：密封橡膠VITON Seal rubber VITON
- ⑥：B：濾心鏢帽式 Filter element nut type

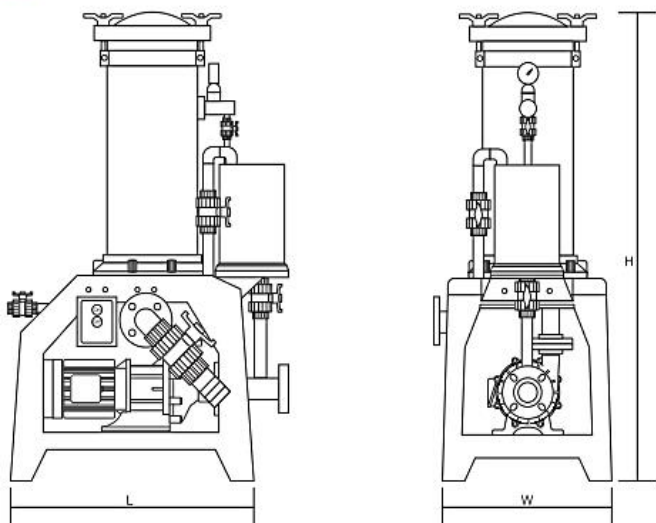

性能參數

PERFORMANCE PARAMETERS

型號 MODEL	TFX-1001	TFX-2001	TFX-1002	TFX-2002	TFX-1004	TFX-2004	TFX-2006	TFX-2008	TFX-2012	TFX-2018	TFX-3018	
溫度範圍 TEMPERATURE	PP濾筒 FILTERING CARTRIDGE	70	70	70	70	70	70	70	70	70	70	
馬達 POWER	50Hz (W)	45	65	65	150	150	260	400	750	750	3700	
過濾量 FILTRATION CAPACITY (L/min)		20	30	30	60	60	80	200	280	300	335	580
濾心數 (支) FILTER ELEMENT QUANTITY (PC)		10"×1	20"×1	10"×2	20"×2	10"×4	20"×4	20"×6	20"×8	20"×12	20"×18	30"×18
出入口徑 OUTLET INLET DIMENSIONS (INCH)		¾"	¾"	¾"	¾"	1"	1"	1½"	1½"	1½"	2"	2"~2½"
外型尺寸 OVERALL DIMENSIONS	長 L (mm)	396	396	396	575	575	575	730	730	825	825	825
	寬 W (mm)	295	295	295	365	365	365	455	455	540	585	585
	高 H (mm)	735	1060	735	1060	800	1065	1450	1450	1500	1500	1760
機體重量 WEIGHT (kg)		16	18	16	31	16	31	75	82	99	118	130



特點

- 過濾機主體採用GF-PP材料射出成型，具有耐高溫、耐酸鹼等特性。
- 安全開關裝置，當馬達過載或單相運轉時，安全開關自動切斷電源。
- 零件100%互換，更換容易。
- 高精度過濾，過濾面積廣、效率高、操作簡便、清洗容易。
- 加裝自清循環回路，活性炭處理裝置，操作簡便。

FEATURES

- Main body colour filter with GF-PP material injection molding, good resistance to high temperature, acid and alkali resistant characteristics.
- Safety drive device that, when the motor overload or single phase operation, safety switch to automatically shut off the power supply.
- 100% interchangeable parts, easy replacement.
- High precision filtration, filtering area wide, high efficiency, simple operation, easy to clean.
- Since the qing circuit, active carbon processing device, easy operation.



型號意義 MODEL EXPLANATION

TFL-2006-P-F-N-B

① ② ③ ④ ⑤ ⑥

- ①：機型型號 Model
- ②：2006-濾心數量20"×6支 Filter element quantity 20"×6pc
- ③：P：泵體材質 GF-PP Pump material GF-PP
- ④：F：出入口法蘭式 Flange type outlet/inlet
U：出入口由任式 Union type outlet/inlet
- ⑤：N：密封橡膠NBR Seal rubber NBR
V：密封橡膠VITON Seal rubber VITON
- ⑥：B：濾心螺帽式 Filter element nut type

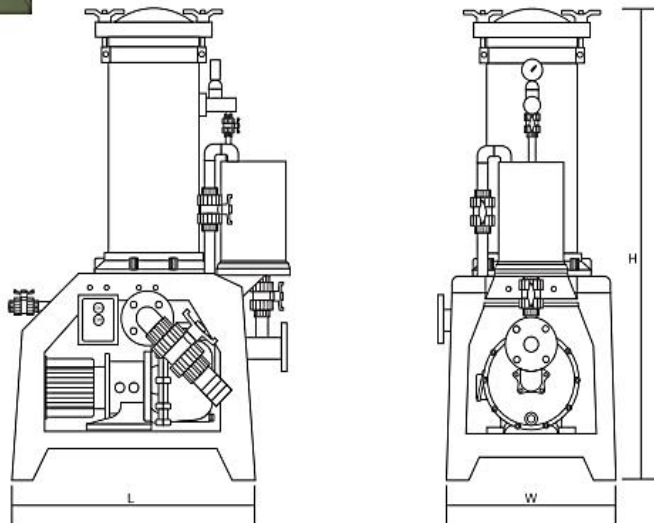

性能參數

PERFORMANCE PARAMETERS

型號 MODEL	TFL-2006	TFL-2008	TFL-2012	TFL-2018	TFL-3018	
溫度範圍 TEMPERATURE	PP濾筒 FILTERING CARTRIDGE	70	70	70	70	
馬達 POWER	50Hz (W)	750	750	1500	2200	3700
過濾量 FILTRATION CAPACITY (L/min)		170	185	240	320	450
濾心數(支) FILTER ELEMENT QUANTITY(PC)		20"×6	20"×8	20"×12	20"×18	30"×18
出入口徑 OUTLET INLET DIMENSIONS (INCH)		1½"	1½"	1½"	2"	2"~2½"
外型尺寸 OVERALL DIMENSIONS	長 L (mm)	730	730	825	825	825
	寬 W (mm)	455	455	540	585	585
	高 H (mm)	1450	1450	1500	1500	1760
機體重量 WEIGHT	(kg)	80	82	103	121	135



操作說明

1. 在確認過濾機安裝完畢且管道早已固定好，電源接線與過濾機電磁開關蓋上所標示的電壓一致後，方可開機。
2. 先將泵浦註滿液體參考《濾心鎖帽式結構圖與零件對照表》，打開排氣閥開關(17)，註水桶球閥(9)，將水由註水桶(7)經註水桶球閥(9)進入泵浦及入口管內，使入口管內完全註滿液體。
3. 啟動馬達之前先將註水桶球閥(9)鎖緊後再打開排氣球閥開關(17)，使氣體從此管道排出。
4. 啟動電源前應先檢查進出管線是否選擇正確。例如：出口球閥是否開啟，管路流通路線是否正確，藥液桶內的液體是否正確，管路有沒有損壞現象。
5. 以上操作完成後，啟動電源開關，注意泵浦運轉方向是否正確，運轉方向如果錯誤，則出口管不會有液體流出，轉換電源接線方向即可解決。
6. 將註水桶(7)內的液體流經註水桶球閥(9)進入泵浦內，註水桶內完全沒液體後再鎖緊註水桶球閥，避免泵浦入口吸入空氣造成空轉。
7. 過濾機在使用前，先檢查壓力表固定座(14)內是否註滿清水或油，請加滿再鎖緊壓力表，以保持壓力表的準確度。
8. 操作在危險的環境或液體，應該穿著有防護衣及防護面罩，安全鞋和手套。
9. 如出口沒有液體或壓力表無壓力，應停機檢查，待確認無誤後方可再次試機，試機前應將泵浦內再次註滿液體。
10. 停機時請先打開排氣球閥(17)，再關閉電源。
11. 清洗濾芯時，請在停機後三分鐘左右再關閉出入口球閥開關，(目的是在讓藥液在大氣壓作用自然滲透濾芯，使液面下降)，再由清洗排放閥(25)將濾桶內藥液排放乾淨，再打開桶蓋，取出濾材清洗乾淨，重新裝機使用。

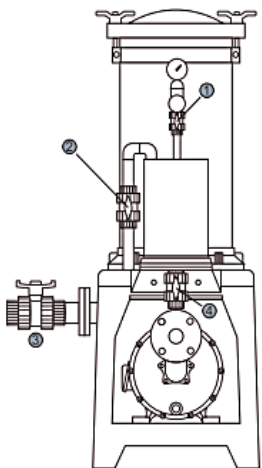

過濾機按常規安裝，但出口必須加裝球閥開關。

操作方法 OPERATION METHOD

- 一、首先濾芯必須清洗乾淨，在過濾機壓力較低的情況下進行。
- 二、當過濾機處在正常過濾情況下，活性碳粉未倒入註水桶，打開排氣球閥①，藥液會從排氣管流到註水桶，此時可用塑料棒將活性碳攪拌均勻。
- 三、打開循環球閥開關②，並關閉出口球閥開關③，再打開註水桶球閥④，使藥液由入口和攪拌桶開關經濾材過濾到出口再回到入口，再循環三到五分鐘。
- 四、打開出口球閥開關③，關閉循環球閥開關②，將攪拌桶內藥液緩慢吸入到泵浦內，關閉註水桶球閥，關閉排氣球閥①，使藥液桶內液體正常循環過濾。

OPERATING INSTRUCTIONS

1. confirmed that filter installation ends and the pipeline had already fixed good, power wiring and filter mechanical and electrical magnetic switch cover indicated on the voltage agreement can boot.
2. first will pump filled with liquid reference 《FILTER HEART LOCK STRUCTURE AND CAP TYPE PARTS CROSS-REFERENCES》, open the discharge valve switch (17), note bucket ball valve (9), will water bucket (7) by note by note bucket ball valve (9) into the pump and entrance tube, make entrance tube completely filled with liquid.
3. start the motor before will note bucket ball valve (9) lock after the exhaust valve switch (17), make the gas pipeline from discharge.
4. before starting power should check whether to choose the correct in and out of the pipeline. For example: gateway ball valve is on, pipeline route is correct circulation, solution the groove liquid is normal, pipeline have damage phenomenon.
5. the above operation after completion, start the power switch, pay attention to the pump running direction is correct, the running direction if error, the export pipe won't have liquid flows, conversion power wiring direction can be solved.
6. will note bucket (7) inside fluid through note bucket ball valve (9) into the pump inside, note bucket didn't entirely within the liquid again after the lock note bucket ball valve, avoid inhaled air pump entrance by idling.
7. filter before use, first check pressure gauge fixed a (14) in water or oil whether note qing dynasty, please fill it up to lock pressure gauge, in order to maintain the accuracy of the pressure gauge.
8. operating in dangerous environment or liquid, should wear protective clothing and protective mask is, safety shoes and gloves.
9. such as export no liquid or without pressure gauge, should stop check, to confirm the trial again, before the trial should be pumped again in filled with liquid.
- 10 when stop, please first open the exhaust valve (17), then turn the power off.
11. cleaning filter, please stop in three minutes after again close in and out of ball valve switch, (objective in let solution at atmospheric pressure effect, make natural penetration filter liquid surface down), again by cleaning discharge valve (25) will filter barrel physic liquor in emissions clean, then open the lid, remove the filter material clean, to use the installed.

1. First filter must clean, in the filter the situation of low pressure.
2. When filter in normal filter cases, active carbon powder into Water bucket, open the exhaust valve ①, solution will exhaust flow from to Water bucket, right now usable plastic rod will be activated carbon and mix well.
3. And open cycle ball valve switch ②, and close export ball valve switch ③, and then open the note bucket ball valve ④, make solution by the entrance and mixing barrel through filtration material to export the filter back to the entrance, recycling three to five minutes.
4. Open the export ball valve switch ③, closed cycle ball valve switch ②, mixing barrel will slow to pump in liquids in, close the note bucket ball valve, close the exhaust valve ①, make solution slot liquid normal circulation filter.



濾心鎖帽式結構圖與零件對照表 FILTER HEART LOCK STRUCTURE AND CAP TYPE PARTS CROSS-REFERENCES

NO	名稱 NAME
1	泵浦 pump
2	過濾機支架 Filter stents
3	過濾機底蓋 Filter base
4	過濾機桶 Filter barrels
5	桶蓋O型圈 Lid O-rings
6	桶蓋 Lid
7	註水桶 Water bucket
8	註水桶底座 Water bucket base
9	註水桶球閥 Water bucket ball valve
10	泵浦吸入口 Suction pump
11	過濾機完成出口 Filter complete exports
12	電源開關盒 Power switch box
13	壓力表 Pressure gauge
14	壓力電座 Pressure electric seat
15	排氣閥總成 Exhaust valve assembly
16	排氣接合管 Exhaust conjugation tube
17	排氣球閥 Exhaust ball valve
18	濾芯 Filter
19	濾芯下墊片 Filter down gaskets
20	鐘帽式固定座 Cap type fixed a self-contained
21	SUS束環 SUS clamps
22	SUS吊環螺絲 SUS rings to unscrew
23	上蓋把手介子 Cover handle muon
24	紅色把手 Red handle
25	清洗排放球閥 Cleaning emissions ball valve
26	電機 motor
27	濾袋 Filter bag
28	濾芯螺母 Filter the nut

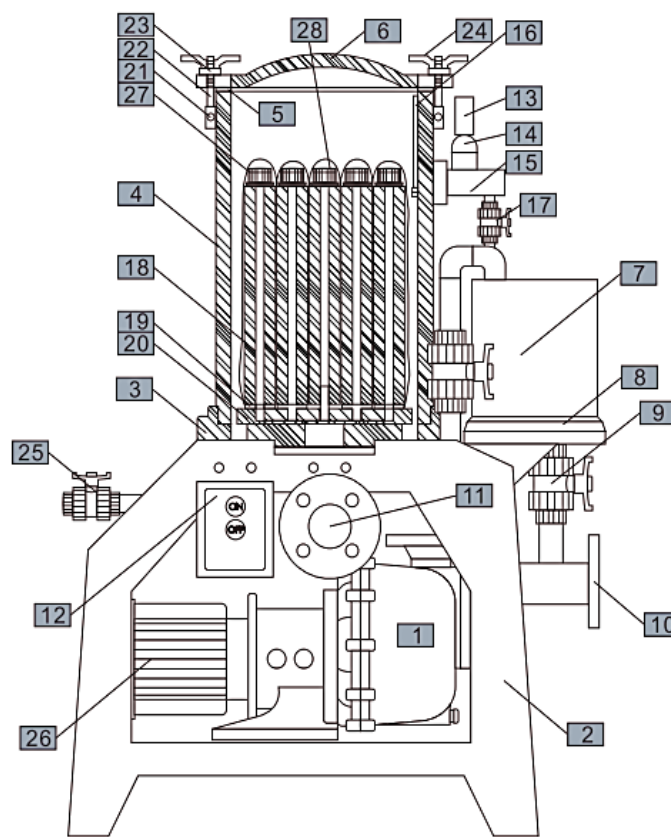

安裝注意事項

Installation Note

化學藥液過濾機

CHEMICAL LIQUID MEDICINE FILTER



安裝注意事項

1. 過濾機管路安裝應以過濾機出入口徑相應尺寸的管件安裝。連接部分不可洩漏，管路安裝完畢應將管路固定支撐好。
2. 入口配管盡量縮短距離，入口管路終端必須加裝底閥或逆止閥及入口濾網，底閥安裝高度應距槽底11cm以上，並遠離空氣攪拌管。
3. 過濾機大部分材料為GF-PP材質，為防止日光曝曬，請盡量安置在室內，如若安裝於室外，應安裝於遮陽棚內。
4. 不同之化學藥液在不同的溫度下，使用配管應注意選擇不同材質的管件，如PP管件適用於70°C以下的化學藥液。
5. 為防止人為因素汙染藥液，配管時應盡量選用幹淨整潔的材料，必要時請將管路清洗幹淨。
6. 用軟質材料配管時，最好選用內襯鋼絲的軟管，槽內部分應用硬質材料且固定於槽邊緣，以免刮起，造成空轉損壞泵浦。
7. 過濾機應安裝在堅固的水平地面上，且機身保持與地面垂直，並加以固定。
8. 過濾機安裝高度因地置宜，但安裝高度最好是選擇濾桶底部平面不要過低於藥槽，且盡量在出入口安裝球閥開關，以便於檢查、維修。
9. 過濾機在出廠前已經過嚴格的檢測，所有附屬配件皆與過濾機配套，請勿擅自更改。
10. 過濾機使用電壓，在過濾機電磁開關護罩上已有標示，如若更改，須與供應商或直接與我公司聯繫。

INSTALLATION NOTE

1. Filter pipe installation should be to filter out the size of the corresponding pipe installation caliber. The connection leak, pipe installation ends shall be fixed support of the pipeline.
2. Entrance piping try to shorten the distance, the entry line terminal must add bottom valve or non-return valve and entrance mesh, bottom valve installation height should be apart from the bottom of the channel 11 cm above, and stay away from the air mixing tube.
3. Filter most materials for GF-PP material, to prevent sunlight insolate, please try to put in indoor, if installed on the outside, should be installed in the midst.
4. Different chemical solution in different temperature, the use of piping should pay attention to choose different material pipe and pipe fittings apply to such as PP 70 °C the following chemical solution.
5. To prevent human factors pollution solution, piping should choose the material as far as possible clean and tidy and, when necessary, please clean the pipeline.
6. With soft material, piping, had better choose lining hose wire, groove in application of hard material and fixed in the edge slot, lest tilted and cause damage idling pump.
7. Filter machine should be installed in the strong level the ground, and keep the fuselage with ground vertical, and be fixed.
8. Filter installation height because buy appropriate, but the installation height had better be to choose the bottom plane don't filter barrels below medicine slot, and as far as possible in inward and outward installation ball valve switch in order to inspect and repair.
9. Filter in before they leave the factory has been strict test, all parts are affiliated with filtering machine form a complete set, please do not change without permission.
10. Filter machine use voltage, in the filter mechanical and electrical magnetic switch cover existing markings on, if change, must be the supplier or direct contact with me.

使用注意事項

CAUTIONS

化學藥液過濾機

CHEMICAL LIQUID MEDICINE FILTER



使用注意事項

1. 在使用前請熟悉機器的操作，請認真閱讀操作說明書，內有詳細的說明供您了解過濾機的安裝使用與維護。
2. 運作時請勿隨意改變藥液的使用，以避免不同的化學藥液混合造成過濾機的損壞，抽送藥液的化學性請在採購前與本公司聯繫，以配備相應的過濾機。
3. 過濾機的使用請嚴格遵守：勿超壓、空轉、化學性不配合，不同化學性互用以及不標準的零件的使用，以免產生危險。
4. 大部分藥液在電解時會有氫氣析出，過濾機長期不用時，請打開壓力排氣閥，以免氫氣聚集到一定程度，在特定條件下產生氫爆。
5. 在使用過濾機時，應經常檢查過濾狀況如：壓力，出口流量。如壓力表無壓力應停機檢查壓力表膜片內是否有水，壓力表是否損壞，泵浦管道是否損壞（開機前應嚴格檢查管路，出入口球閥是否開啟，空轉會損壞泵浦，長時間超壓工作會使過濾機產生爆裂的危害）。
6. 過濾機在工作時間內應有人維護，節假日及夜間無人操作時，請切斷電源，以免因故造成損失。
7. 過濾壓力請參照壓力表上的紅色指針，如壓力高於紅色指針，請立即清洗濾材，如濾材經使用一段時間，經清洗後裝機再用，壓力很快升到清洗前的壓力，說明濾材大部分毛孔已阻塞，再無使用價值，請更換濾材，同時使用藥液溫度不可高於70°C。

CAUTIONS

1. Before use please familiar with the operation of the machine, please read the operating instructions, with detailed instructions for you to understand filter installation using and maintenance.
2. Please do not change operation of the use of liquids, in order to avoid different chemical solution mixed cause the damage of the filter, pumping the liquid chemical please before purchasing contact with the company, with corresponding to the filter.
3. Filter use please strictly observe: do not exceed pressure, idling, chemical don't cooperate, different chemical each other to use and not the use of the standard parts, lest produce risk.
4. Most in electrolytic solution will there be hydrogen exhalation, filter long-term need not when, please open the pressure exhaust valve, in order to avoid the hydrogen gathered to a certain degree, in particular conditions produce hydrogen explosion.
5. In use filter unit, often should check the filter conditions such as pressure, outlet flow. Such as pressure gauge without pressure should be shut down in check pressure gauge diaphragm whether there is water, pressure gauges for damage and pump pipeline for damage (should be strict inspection before starting the pipeline, entrances ball valve is on, idling might damage the pumps, long time work will make super pressure filter generation blowout harm).
6. Filter in the work within the time someone maintenance, holiday and no one night when operating, please cut off power to avoid for losses.
7. Filter pressure gauges, please refer to the red pointer, such as pressure is higher than the red pointer, please immediately cleaning filter materials, such as filtration material by the use of a period of time, after cleaning the installed to use, and the pressure to clean up soon before the pressure, filtration material that most of the pore already jams, there is no use value, please replace filter material, use at the same time not higher than 70 °C temperature liquids.

安裝圖例

INSTALLATION ILLUSTRATIONS

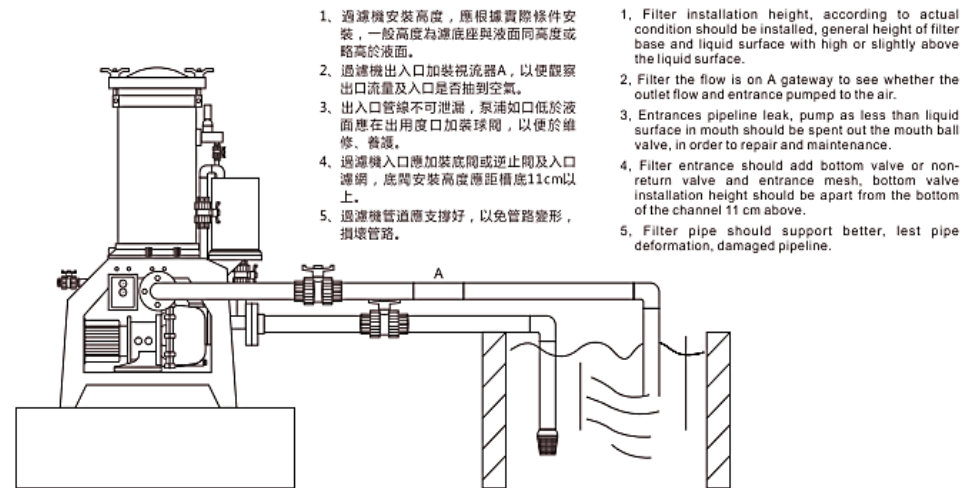

1. 過濾機安裝高度，應根據實際條件安裝，一般高度為濾底座與液面同高度或略高於液面。
2. 過濾機出入口加裝視流器A，以便觀察出口流量及入口是否抽到空氣。
3. 出入口管線不可洩漏，泵浦如口低於液面應在出用度口加裝球閥，以便於維修、替換。
4. 過濾機入口應加裝底閥或逆止閥及入口濾網，底閥安裝高度應距槽底11cm以上。
5. 過濾機管適應支撐好，以免管路變形，損壞管路。

1. Filter installation height, according to actual condition should be installed, general height of filter base and liquid surface with high or slightly above the liquid surface.
2. Filter the flow is on A gateway to see whether the outlet flow and entrance pumped to the air.
3. Entrances pipeline leak, pump as less than liquid surface in mouth should be spent out the mouth ball valve, in order to repair and maintenance.
4. Filter entrance should add bottom valve or non-return valve and entrance mesh, bottom valve installation height should be apart from the bottom of the channel 11 cm above.
5. Filter pipe should support better, lest pipe deformation, damaged pipeline.

保養與維修

MAINTENANCE AND REPAIR

1. 作業員一定要熟悉產品性能，懂修理技術的專業維修員。
2. 定期檢測泵浦有無洩漏，泵浦是否有異常。
3. 經常檢查出口流量是否正常，入口液位是否太低，會否抽到空氣。
4. 維修人員維修前應穿好防護衣褲，避免遭到傷害。
5. 維修前首先切斷電源，再將泵浦出入口球閥關閉，將泵浦內藥液排放幹淨。
6. 拆卸泵浦時，葉輪固定螺絲以逆時針方向為緊，葉輪與中封蓋的間隙為3.5mm，太小會產生摩擦，葉輪與後封蓋的間隙也保持在3.5mm左右。
7. 組裝時，軸封陶瓷固定環與軸心在同一圓心上。
8. 在鎖緊後封蓋和主體螺絲時，不要用力過大，以免損壞泵浦。

1. The operator must be familiar with the product performance, understand the repair technology professional maintenance team.
2. Regular testing pump leaks, pumps are normal.
3. Often check export flow is normal, the entry level is too low, will you take to the air.
4. Maintenance personnel should wear protective clothing before maintenance socks, avoid are hurt.
5. Before maintenance cut off power supply, again will pump entrances ball valve closed, will pump discharge physic liquor in clean.
6. Remove the pumps, impeller to unscrew fixed to counterclockwise for tight, the impeller and drawing the clearance of 3.5 mm, too small causes friction, impeller and drawing the clearance after also remained in the 3.5 mm or so.
7. Assembly, shaft seal ring and ceramic fixed axis in the same circle.
8. In lock block and main body after unscrew, don't greatly too forcibly, lest damage pump.